



# ACTIVE AIR TREATMENT SYSTEM

ACTIVATE PURE, FRESH AIR IN YOUR WHOLE HOME

## ACTIVE AIR TREATMENT FOR THE WHOLE HOME

AKTIV8™ actively improves the indoor air quality and HVAC equipment efficiency within the home or building. It neutralizes biological contaminants such as mold, bacteria and viruses that circulate through the ventilation system. AKTIV8 (patent pending) is highly effective in helping to maintain a clean coil free from odor-causing and efficiency-robbing mold and biofilm.



### FEATURES/BENEFITS

<b>Actively treats the whole-system</b>	Treats the HVAC equipment and air in the entire home all the time
<b>Advanced 2-year UV germicidal oxidizing quartz lamp</b>	Long lasting, safe and effective
<b>Activated carbon catalyst</b>	Complete biological and odor control
<b>Certified to UL 2998</b>	Verified zero ozone
<b>Easy installation</b>	Simple 24V connection and duct board kit included

## TREAT THE AIR AND KEEP YOUR HVAC SYSTEM CLEAN

### REDUCE:



**Odors**



**VOCs**



**Germs**



**Viruses**



### AKTIV8 SINGLE

Our most popular model when there is enough room over the coil for HVAC treatment.

FURNACE APPLICATION

AIR HANDLER APPLICATION

### AKTIV8 DUAL

The best choice when there is not enough room over the coil. It includes a 2nd UVC light for coil disinfection.

## AKTIV8™ GOES BEYOND FILTERS TO TREAT THE OTHER 2/3RD'S

Conventional filters are only effective against particulates, like dust. AKTIV8 safely reduces both biological and chemical contaminants inside the air system and throughout the building. Together, they address 99+% of the contaminants in the air.

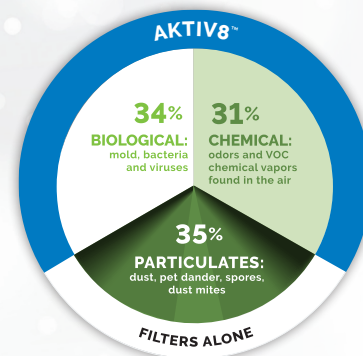



# ACTIVE AIR TREATMENT SYSTEM

ACTIVATE PURE, FRESH AIR IN YOUR WHOLE HOME

## SPECS

AKTIV8 In-Duct Single*	
UV Lamp	11" UVC germicidal/oxidizing lamp (patent pending)
Dimensions	Carbon catalyst and lamp: 11.25"W x 5.87"H x 5.87"D
ER Models Electrical	18-32 VAC, 60 Hz, 0.8 Amps, 20 VA
Pressure Drop	<0.01" w.c. @ 400 FPM
Warranty	Main unit: 5-years UV lamp: 2-years
Part Number	<b>TUV-AKT8-ER2</b>
AKTIV8 Replacement UV Lamp	
Part Number	TUUVL-211-OS-N9

AKTIV8 In-Duct Dual*	
UV Lamp	11" UVC germicidal/oxidizing lamp (patent pending)
Coil Mount UV Lamp	11" UVC germicidal lamp
Dimensions	Carbon catalyst and lamp: 11.25"W x 5.87"H x 5.87"D
ER Models Electrical	18-32 VAC, 60 Hz, 0.8 Amps, 20 VA
Pressure Drop	<0.01" w.c. @ 400 FPM
Warranty	Main unit: 5-years UV lamps: 2-years
Part Number	<b>TUV-AKT8-DER2</b>
AKTIV8 Replacement UV Lamp	
Part Number	TUUVL-211-OS-N9
Coil Mount Replacement UV Lamp (Dual Only)	
Part Number	TUUVL-211P

\* PATENT PENDING

\* PATENT PENDING

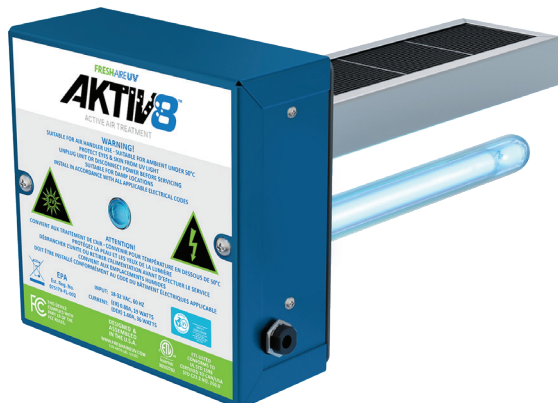
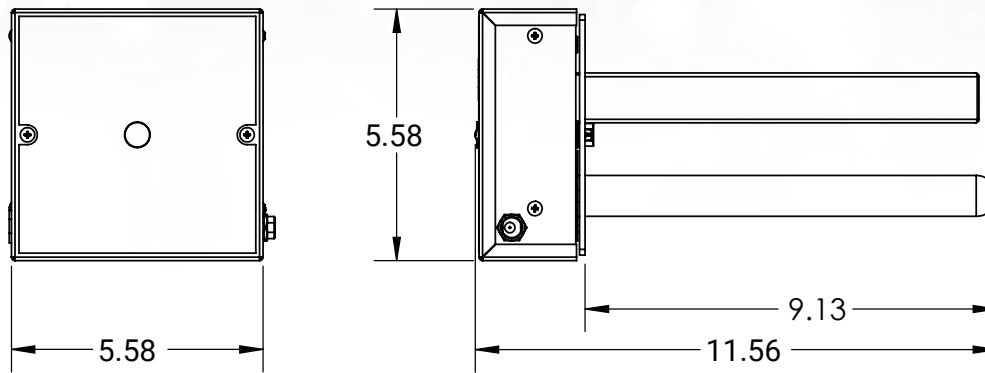

**DESIGNED & ASSEMBLED IN THE U.S.A.**